

# Logistics / Sales & Services

## Logistics, Sales and Service Activities

**POINT**

- (1) Subaru Logistics Co., Ltd. is conducting activities to expand the joint transportation of completed vehicles and to improve the efficiency of container transportation.
- (2) We have been conducting the Customer Service Quality Improvement Project at Subaru dealers' new vehicle sales outlets across Japan since 2005.
- (3) We will continue collecting reassembled and used parts, including bumpers, by cooperating with domestic Subaru dealers.

### The Logistics Stage

Logistics Efforts (1) by Subaru Logistics Co., Ltd.

#### Improving Transportation Efficiency by Increasing the Total Number of Vehicles Carried by Joint Transportation

Subaru Logistics has contributed to reducing generation of environmentally hazardous substances caused during the transportation of new cars, by improving transportation efficiency through such means as setting optimum standard transportation routes, promoting modal shifts and improving carrying efficiency. In fiscal 2006, by promoting the joint transportation of completed vehicles with other companies in the same industry, the company increased the total number of completed vehicles carried (total number of vehicles consigned to other companies and to our company) to 41,660, an increase of approximately 17% over the previous fiscal year.

In fiscal 2006, in order to comply with the Revised Energy-Saving Law, the company encouraged its affiliated transportation companies to install digital tachographs and

devices that stop engines while idling in their vehicle-carrying trucks, and consequently obtained highly precise energy consumption figures (including CO<sub>2</sub> emissions figures) by systematically collecting mileage and fuel consumption data from partner companies, using that data to reduce energy consumption per sales by over 1% for the year.

Trends in the Number of Vehicles Carried Through Joint Transportation

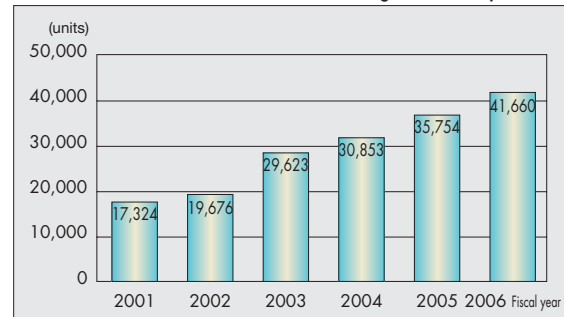

Logistics Efforts (2) by Subaru Logistics Co., Ltd.

#### Reducing the Environmental Impact of Transportation of Marine Freight Containers

The environmental impact of transporting marine freight containers can be reduced by increasing the rate containers are fully loaded each round trip and by reducing the total number of trips. Companies handling international marine cargo are roughly divided into those focused more on exports and those focused more on imports. Because the volume of cargo each company handles is skewed one way or the other, towards exports or towards imports, many containers will be empty during transportation to or from the

loading/unloading point and the export/import port, leading to waste and inefficiency. Since it is impossible for a single company to solve this complex problem through its own efforts, we have involved not only partner companies but also shipping companies to work to reduce CO<sub>2</sub> emissions by engaging in joint transportation between companies with more exports (Our Company) and companies with more imports so that containers are always fully loaded in both directions. In fiscal 2007, we expect to reduce the number of trips by approximately 4% compared to the previous fiscal year, and intend to further expand our joint transportation scheme.

Diagram of Logistics Operations Conducted through Joint Transportation of Marine Freight Containers between a Company with Excess Imports and a Company with Excess Exports (Our Company)

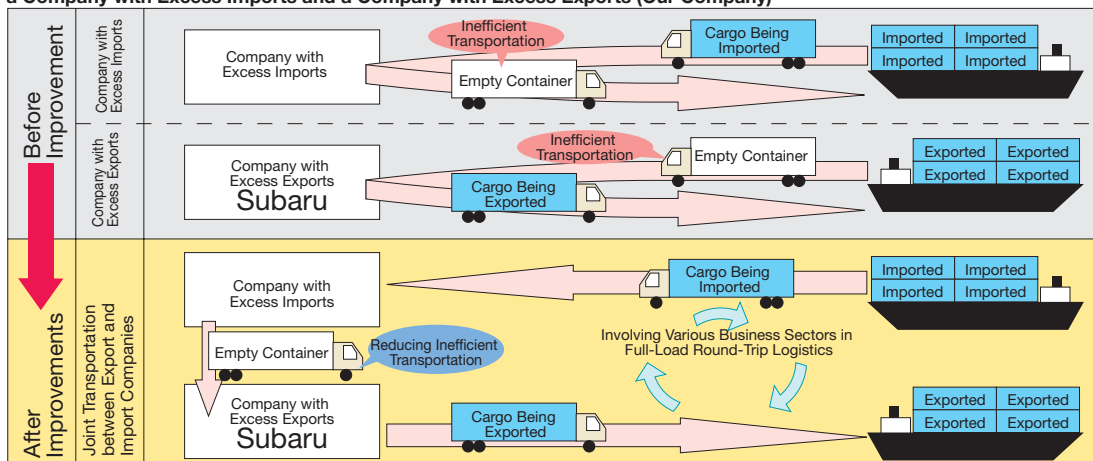

**Sales and Service Activities Stage**

Environmental Activities of Subaru Dealers

**Ongoing “Subaru Eco Action 21” Activities**

In order to achieve “clean” dealers, Subaru has been working on a program of environmental conservation activities, called “Subaru Eco Action 21,” together with Subaru dealers across Japan, which are in face-to-face communication with customers and local residents.

In December 2003, we started “thorough inspections on environmental compliance” at model sales outlets (shops and service workshops), and have promoted both inspection and environmental improvement activities at all dealer’s outlets as Subaru dealers’ voluntary activities since 2005. At the end of March 2006, we verified the current situation at all sales outlets and continued to take countermeasures at sales outlets in need of improvement into fiscal 2006.

From fiscal 2005 to the first half of 2006, we dispatched our staff to all new vehicle sales outlets at Subaru dealers under the Customer Service Quality Improvement Project, and worked to further enhance sales and services by verifying that waste materials were being separated and confirming storage conditions at shops and service workshops, in order to improve customer satisfaction.

In terms of establishing Environmental Management Systems at domestic Subaru dealers, after Niigata Subaru Co., Ltd. obtained ISO14001 certification in 2005, subsequently added its Shibata outlet in June of 2006, then Subaru Kumamoto Corporation newly obtained the certification in November of 2006. As a result, six Subaru dealers in total have obtained ISO14001 certification: Chiba Subaru, Inc., Aomori Subaru Co., Ltd., Fuji Subaru Co., Ltd., Osaka Subaru Co., Ltd., Niigata Subaru Co., Ltd. and Subaru Kumamoto Corporation.

Using Reassembled and Used Parts

**Collect Reassembled and Used Parts with Subaru Dealers**

Subaru and Subaru dealers across Japan are using recycled (that is, reassembled) and used parts. Using reassembled parts such as engines, transmissions and water pumps, was started in collaboration with the related manufacturers in fiscal 2004.

Using used parts such as exterior panels, lamps and wheels, was started in collaboration with existing used parts network groups.

**Items that Utilize Reassembled Parts**

Designated items

Engine, Transmissions, CVT (Continuously Variable Transmission), Alternator, Starter, ECU (Engine Control Unit), Water Pump and etc.

Collection of the Scrapped Bumpers

**Recycle Scrapped Bumpers for Use in Other Parts**

Subaru established an in-house system in 1973 to identify the materials used in plastic parts, ahead of the timetable for industry guidelines for the establishment of such systems. This system is very helpful when the company collects scrapped bumpers to recycle for use in other parts of vehicles. In fiscal 2006, we collected 44,242 scrapped bumpers from all over Japan, which is 99.7% toward the previous year (44,373). The scrapped bumpers were recycled for use in other parts of Subaru as shown in the graph below.

**Parts Produced from Scrapped Bumpers**

Models	Parts
R1, R2, Pleo	Universal joint cover, Underfloor cover
Legacy	Under spoiler, Battery pan

**Trends in Number of the Scrapped Bumpers Collected**

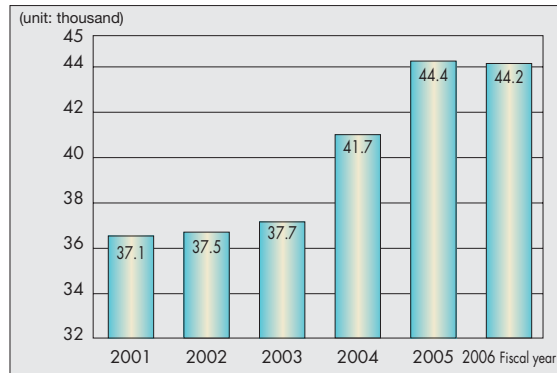

Outback 2.5i S-style LIMITED